

> RLA ST

AIR-WATER CHILLERS AND HEAT PUMPS
FOR OUTDOOR INSTALLATION

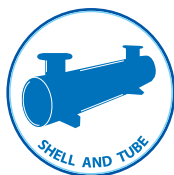

Available range

Unit type

IR	Chiller
IP	Heat pump (reversible on the refrigerant side)
BR	Chiller Brine
BP	Heat pump Brine (reversible on the refrigerant side)

Version

VB	Base version
VD	Desuperheater version (with plate heat exchanger)
VR	Total recovery version (with plate heat exchanger)

Acoustic setting up

AB	Base setting up
AS	Low noise setting up
AX	eXtra low noise setting up

Source temperature level

M	Medium temperature level
A	High temperature level

Unit description

This series of air-water chillers and heat pumps satisfies the cooling and heating requirements of residential plants of medium-large size.

All the units are suitable for outdoor installation and can be applied to fan coil plants, radiant floor plants and high efficiency radiators plants.

The refrigerant circuit, contained in a compartment protected from the air flow to simplify the maintenance operations, is equipped with scroll compressors mounted on damper supports, shell and tube heat exchanger with threaded or viciaulic fittings (according to the model),

electronic expansion valve, reverse cycle valve, dehydrator filter, axial fans with safety protection grilles, finned coil made of copper pipes and aluminium louvered fins with subcooling section. The circuit is protected by a safety gas valve, high and low pressure switches and differential pressure switch on the heat exchanger. The heat exchanger and all the hydraulic pipes are thermally insulated in order to avoid condensate generation and to reduce thermal losses.

All the units can be equipped with variable speed fans control that allows the units to operate with low outdoor temperatures in cooling and high outdoor temperature in heating and permits to reduce noise emissions in such operating conditions.

The low noise acoustic setting up (AS) is obtained, starting from the base setting up (AB), reducing the rotational speed of the fans and mounting sound jackets on the compressors and the technical compartment is clad with soundproofing material of suitable thickness.

The eXtra low noise acoustic setting up (AX) is obtained, starting from the low noise setting up (AS), further reducing the rotational speed of the fans and using finned coil with bigger surface.

All the units are supplied with a management and control electrical panel containing general switch, phase presence and correct sequence controller, microprocessor controller with display and all the other electrical components with IP54 minimum protection degree.

All the units are accurately built and individually tested in the factory. Only electric and hydraulic connections are required for installation.

Options

Storing module available in the configurations :

- 1 or 2 pumps
- standard or high head pump

Refrigerant circuit pressures visualization

- high and low pressure gauges
- high and low pressure transducers

High temperature thermostat

Compressor starting

- standard (contactors)
- soft starter

Fans control

- on-off control
- modulating control (condensation / evaporation control)

Compressor power factor correction

Electrical load protection

- fuses
- thermal magnetic circuit breakers

Coil condensate tray

Accessories

Rubber vibration dampers

Spring vibration dampers

Coil protection grilles

Remote control

Modbus serial interface on RS485

Programmer clock

Phase sequence and voltage controller

Water flow switch

Viciaulic hydraulic fittings

Separated storing module

Separated storing and pumping module

NET NOMINAL performances - Standard plants - EUROVENT certified data

IR	Base setting up (AB)	160.4	180.4	200.4	230.4	260.4	290.4	330.4	375.4	420.4	
A35W7	Cooling capacity	161	178	199	228	255	289	323	368	409	kW
	Power input	56,2	62,7	70,9	80,4	90,7	103	115	130	146	kW
	EER	2,86	2,84	2,81	2,84	2,81	2,81	2,81	2,83	2,80	W/W
	ESEER	3,84	3,81	3,79	3,82	3,79	3,80	3,79	3,80	3,79	W/W
	Water flow rate	7,74	8,55	9,60	11,0	12,3	14,0	15,6	17,7	19,7	l/s
	Pressure drops	50	61	36	46	56	52	31	37	48	kPa
IR	Low noise setting up (AS)	160.4	180.4	200.4	230.4	260.4	290.4	330.4	375.4	420.4	
A35W7	Cooling capacity	155	171	191	219	245	277	311	353	393	kW
	Power input	59,2	66,1	75,0	85,2	95,5	109	121	137	154	kW
	EER	2,62	2,59	2,55	2,57	2,57	2,54	2,57	2,58	2,55	W/W
	ESEER	3,85	3,80	3,77	3,80	3,79	3,76	3,78	3,80	3,76	W/W
	Water flow rate	7,45	8,22	9,22	10,6	11,8	13,4	15,0	17,0	18,9	l/s
	Pressure drops	46	57	33	43	52	48	29	35	44	kPa
IR	eXtra low noise setting up (AX)	160.4	180.4	200.4	230.4	260.4	290.4	330.4	375.4	420.4	
A35W7	Cooling capacity	151	167	187	214	240	272	304	346	385	kW
	Power input	59,8	66,9	76,0	86,4	96,6	111	123	138	157	kW
	EER	2,53	2,50	2,46	2,48	2,48	2,45	2,47	2,51	2,45	W/W
	ESEER	3,90	3,85	3,82	3,84	3,86	3,82	3,82	3,88	3,81	W/W
	Water flow rate	7,26	8,03	9,03	10,3	11,6	13,1	14,6	16,7	18,5	l/s
	Pressure drops	44	54	32	40	50	45	28	33	42	kPa
IP	Base setting up (AB)	160.4	180.4	200.4	230.4	260.4	290.4	330.4	375.4	420.4	
A35W7	Cooling capacity	154	171	192	215	244	275	310	357	397	kW
	Power input	55,4	61,8	69,6	78,5	89,9	102	113	129	144	kW
	EER	2,78	2,77	2,76	2,74	2,71	2,70	2,74	2,77	2,76	W/W
	ESEER	3,72	3,70	3,72	3,68	3,65	3,65	3,66	3,72	3,73	W/W
	Water flow rate	7,41	8,22	9,27	10,4	11,8	13,3	14,9	17,2	19,2	l/s
	Pressure drops	46	57	33	41	52	47	29	35	45	kPa
A7W45	Heating capacity	169	191	215	240	273	308	345	395	439	kW
	Power input	56,8	64,0	72,3	81,2	92,7	104	116	132	147	kW
	COP	2,98	2,98	2,97	2,96	2,94	2,96	2,97	2,99	2,99	W/W
	Water flow rate	8,03	9,03	10,2	11,4	12,9	14,6	16,3	18,7	20,8	l/s
	Pressure drops	54	68	40	49	62	56	34	42	53	kPa
	IP	Low noise setting up (AS)	160.4	180.4	200.4	230.4	260.4	290.4	330.4	375.4	420.4
A35W7	Cooling capacity	148	164	185	206	234	265	298	343	382	kW
	Power input	58,3	65,2	73,6	86,4	94,7	107	123	136	152	kW
	EER	2,54	2,52	2,51	2,38	2,47	2,48	2,42	2,52	2,51	W/W
	ESEER	3,72	3,69	3,69	3,51	3,64	3,63	3,55	3,73	3,70	W/W
	Water flow rate	7,12	7,88	8,89	9,94	11,3	12,8	14,3	16,5	18,4	l/s
	Pressure drops	42	52	31	37	47	43	26	33	42	kPa
A7W45	Heating capacity	162	183	206	230	262	296	331	379	422	kW
	Power input	53,5	60,3	68,2	76,6	87,3	99	110	125	140	kW
	COP	3,03	3,03	3,02	3,00	3,00	2,99	3,01	3,03	3,01	W/W
	Water flow rate	7,69	8,65	9,75	10,9	12,4	14,0	15,7	17,9	20,0	l/s
	Pressure drops	50	63	37	45	57	52	32	38	49	kPa
	IP	eXtra low noise setting up (AX)	160.4	180.4	200.4	230.4	260.4	290.4	330.4	375.4	420.4
A35W7	Cooling capacity	145	161	181	203	229	259	291	335	374	kW
	Power input	59,0	66,1	74,6	84,4	95,8	109	122	137	153	kW
	EER	2,46	2,44	2,43	2,41	2,39	2,38	2,39	2,45	2,44	W/W
	ESEER	3,79	3,75	3,75	3,71	3,70	3,69	3,69	3,79	3,77	W/W
	Water flow rate	6,98	7,74	8,70	9,75	11,0	12,5	14,0	16,1	18,0	l/s
	Pressure drops	41	50	29	36	45	41	25	31	40	kPa
A7W45	Heating capacity	161	181	204	228	259	293	328	374	417	kW
	Power input	51,8	58,5	66,2	74,5	84,6	95,6	106	121	135	kW
	COP	3,11	3,09	3,08	3,06	3,06	3,06	3,09	3,09	3,09	W/W
	Water flow rate	7,64	8,60	9,65	10,8	12,3	13,9	15,5	17,7	19,7	l/s
	Pressure drops	49	62	36	44	56	51	31	37	48	kPa

Data declared according to EN 14511. The values are referred to units without options and accessories.

EER (Energy Efficiency Ratio) = ratio of the total cooling capacity to the effective power input of the unit

COP (Coefficient Of Performance) = ratio of the total heating capacity to the effective power input of the unit

ESEER (European Seasonal Energy Efficiency Ratio)

A35W7 = source : air in 35°C d.b. / plant : water in 12°C out 7°C

A35W18 = source : air in 35°C d.b. / plant : water in 23°C out 18°C

A7W45 = source : air in 7°C d.b. 6°C w.b. / plant : water in 40°C out 45°C

A7W35 = source : air in 7°C d.b. 6°C w.b. / plant : water in 30°C out 35°C

Acoustic performances

Base setting up (AB)	160.4	180.4	200.4	230.4	260.4	290.4	330.4	375.4	420.4	
Sound power level	91	92	92	92	93	94	94	95	95	dB(A)
Sound pressure level at 1 meter	72	73	73	73	74	75	74	75	75	dB(A)
Sound pressure level at 5 meters	64	65	65	65	66	67	67	68	68	dB(A)
Sound pressure level at 10 meters	59	60	60	60	61	62	62	63	63	dB(A)
Low noise setting up (AS)	160.4	180.4	200.4	230.4	260.4	290.4	330.4	375.4	420.4	
Sound power level	85	86	86	86	87	88	88	89	89	dB(A)
Sound pressure level at 1 meter	66	67	67	67	68	69	68	69	69	dB(A)
Sound pressure level at 5 meters	58	59	59	59	60	61	61	62	62	dB(A)
Sound pressure level at 10 meters	53	54	54	54	55	56	56	57	57	dB(A)
eXtra low noise setting up (AX)	160.4	180.4	200.4	230.4	260.4	290.4	330.4	375.4	420.4	
Sound power level	82	83	83	83	84	85	85	86	86	dB(A)
Sound pressure level at 1 meter	63	64	64	64	65	66	65	66	66	dB(A)
Sound pressure level at 5 meters	55	56	56	56	57	58	58	59	59	dB(A)
Livello di pressione sonora a 10 metri	50	51	51	51	52	53	53	54	54	dB(A)

The acoustic performances are referred to units operating in cooling mode at nominal conditions A35W7.

Unit placed in free field on reflecting surface (directional factor equal to 2).

The sound power level is measured according to ISO 9614 standard.

The sound pressure level is calculated according to ISO 3744 and is referred to a distance of 1/5/10 metres from the external surface of the unit.

Technical data

Unit	160.4	180.4	200.4	230.4	260.4	290.4	330.4	375.4	420.4	
Power supply	400 - 3 - 50									V-ph-Hz
Compressor type	scroll									-
N° compressors / N° refrigerant circuits	4 / 2									n°
Plant side heat exchanger type	shell and tube									-
Source side heat exchanger type	finned coil									-
Fans type	axial									-
N° fans	4			6			8			n°
Water volume plant side heat exchanger	35.6	35.6	61.5	57.8	57.8	52.8	93.9	87.5	80.2	l
Hydraulic fittings plant side heat exchanger	3" GAS		4" VIC			5" VIC				-

Electrical data

Standard unit	160.4	180.4	200.4	230.4	260.4	290.4	330.4	375.4	420.4	
FLA - Full load current at maximum tolerated conditions	140	151	177	193	217	243	269	314	335	A
FLI - Full load power input at maximum tolerated conditions	76	87	107	118	133	148	163	186	200	kW
MIC - Maximum instantaneous current of the unit	283	340	347	355	379	469	495	510	558	A
MIC SS - Maximum instantaneous current of the unit with soft starter options	213	250	263	271	295	354	380	404	438	A
Unit with high head modulating pump	160.4	180.4	200.4	230.4	260.4	290.4	330.4	375.4	420.4	
FLA - Full load current at maximum tolerated conditions	149	160	187	203	227	256	282	327	357	A
FLI - Full load power input at maximum tolerated conditions	81	91	113	124	139	156	171	194	212	kW
MIC - Maximum instantaneous current of the unit	292	348	357	365	389	482	508	524	580	A
MIC SS - Maximum instantaneous current of the unit with soft starter options	222	258	273	281	305	368	394	417	460	A

Operative range

Temperature	Unit type	Cooling		Heating		
		min	max	min	max	
Outdoor air inlet temperature	IR, BR, IP, BP	-10*	55**	-10	40*	(°C)
Water outlet temperature	IR, IP	5	15	30	55	(°C)
Water outlet temperature	BR, BP	-12	5	30	55	(°C)
Water outlet temperature (VD)	IR, BR, IP, BP	30	70	30	70	(°C)
Water outlet temperature (VR)	IR, BR	30	55	-	-	(°C)

* with fans modulating control option (condensation / evaporation control)

** with ATC outdoor high temperature protection function

VD and VR versions

These units allow to recover the heating power, otherwise wasted on air, through an additional plate heat exchanger.

The **Desuperheater Version (VD)** allow the hot water production at temperatures between 30 and 70°C through the partial heat recovery of the condensation heat.

The **Total Recovery Version (VR)** allows the cold water production and, at the same time, the hot water production at temperatures between 30 and 55°C through the total recovery of the condensation heat.

Desupeheater Version (VD) - NET NOMINAL performances

IR	Base setting up (AB)	160.4	180.4	200.4	230.4	260.4	290.4	330.4	375.4	420.4	
A35W7 - W45	Cooling capacity	167	185	207	237	264	300	336	382	425	kW
	Total power input	55,0	61,2	69,3	78,5	88,7	101	112	127	143	kW
	EER	3,04	3,01	2,99	3,02	2,98	2,97	3,00	3,01	2,98	W/W
	HRE	3,90	3,89	3,87	3,91	3,85	3,85	3,90	3,88	3,86	W/W
	Water flow rate	8,05	8,89	10,0	11,4	12,8	14,5	16,2	18,4	20,5	l/s
	Water pressure drop	54	66	39	49	61	56	34	40	52	kPa
	Heating recovery capacity	47,2	53,4	61,2	70,3	76,6	88,7	99,9	110,8	126,6	kW
	Water flow rate recovery	2,25	2,55	2,93	3,36	3,66	4,24	4,77	5,29	6,05	l/s
	Water pressure drop recovery	5	7	8	10	13	16	16	21	25	kPa
	IP	Base setting up (AB)	160.4	180.4	200.4	230.4	260.4	290.4	330.4	375.4	420.4
A35W7 - W45	Cooling capacity	160	177	200	224	253	286	322	371	413	kW
	Total power input	54,1	60,4	67,9	76,6	87,8	99	111	126	140	kW
	EER	2,96	2,94	2,94	2,92	2,89	2,88	2,91	2,95	2,96	W/W
	HRE	3,82	3,81	3,83	3,82	3,75	3,76	3,81	3,83	3,85	W/W
	Water flow rate	7,70	8,55	9,64	10,8	12,2	13,8	15,5	17,9	19,9	l/s
	Water pressure drop	50	61	36	44	55	50	31	38	49	kPa
	Heating recovery capacity	46,5	52,7	60,1	68,8	76,1	87,5	98,9	109,8	123,7	kW
	Water flow rate recovery	2,22	2,52	2,87	3,29	3,64	4,18	4,73	5,25	5,91	l/s
	Water pressure drop recovery	5	6	8	10	13	16	16	20	24	kPa

Total Recovery Version (VR) - NET NOMINAL performances

IR	Base setting up (AB)	160.4	180.4	200.4	230.4	260.4	290.4	330.4	375.4	420.4	
A35W7 - W45	Cooling capacity	169	186	209	239	267	303	339	386	429	kW
	Total power input	47,3	53,5	61,6	70,7	77,2	89,5	100	111	127	kW
	EER	3,56	3,48	3,39	3,38	3,46	3,39	3,38	3,46	3,37	W/W
	HRE	8,08	7,91	7,75	7,71	7,87	7,72	7,71	7,87	7,69	W/W
	Water flow rate	8,13	8,98	10,1	11,5	12,9	14,6	16,4	18,6	20,7	l/s
	Water pressure drop	55	68	40	50	62	56	35	41	53	kPa
	Heating recovery capacity	214	237	268	306	340	388	434	492	550	kW
	Water flow rate recovery	10,2	11,3	12,8	14,6	16,2	18,5	20,7	23,5	26,3	l/s
	Water pressure drop recovery	35	49	41	45	50	48	52	47	52	kPa

Data declared according to EN 14511. The values are referred to units without options and accessories.

EER (Energy Efficiency Ratio) = ratio of the total cooling capacity to the effective power input of the unit

HRE (Heat Recovery Efficiency) = ratio of the total capacity of the system (heating plus cooling capacity) to the effective power input

A35W7 - W45 = source : air in 35°C d.b. / plant : water in 12°C out 7°C / Recovery : water in 40°C out 45°C

CONTROL SYSTEM

The units are equipped with a controller designed to ensure energy saving and unit efficiency. Available functions :

- ATC outdoor high temperature protection function
- Dynamic defrost
- Sound management
- Climatic control in heating and in cooling mode
- Double set point function
- Demand limit
- Integrative heating
- Remote stand by
- Remote cooling-heating



DIMENSIONS - MINIMUM OPERATING AREA - WEIGHT

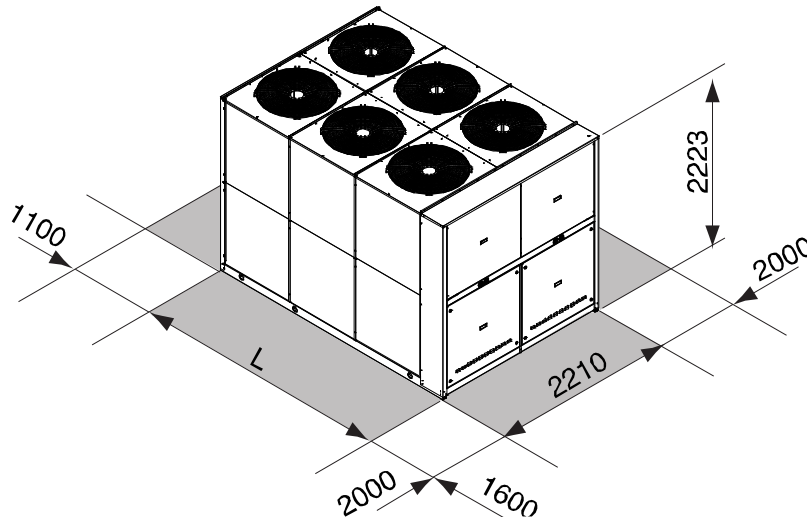

	160.4	180.4	200.4	230.4	260.4	290.4	330.4	375.4	420.4	
L	3164	3164	3164	3164	3164	3164	4097	4097	4097	mm
Operating maximum weight*	2157	2346	2644	2815	2885	2901	3182	3292	3357	kg

* Weight refers to the unit IP complete with 2 pumps module without tank.